

Public Water Supply Manual

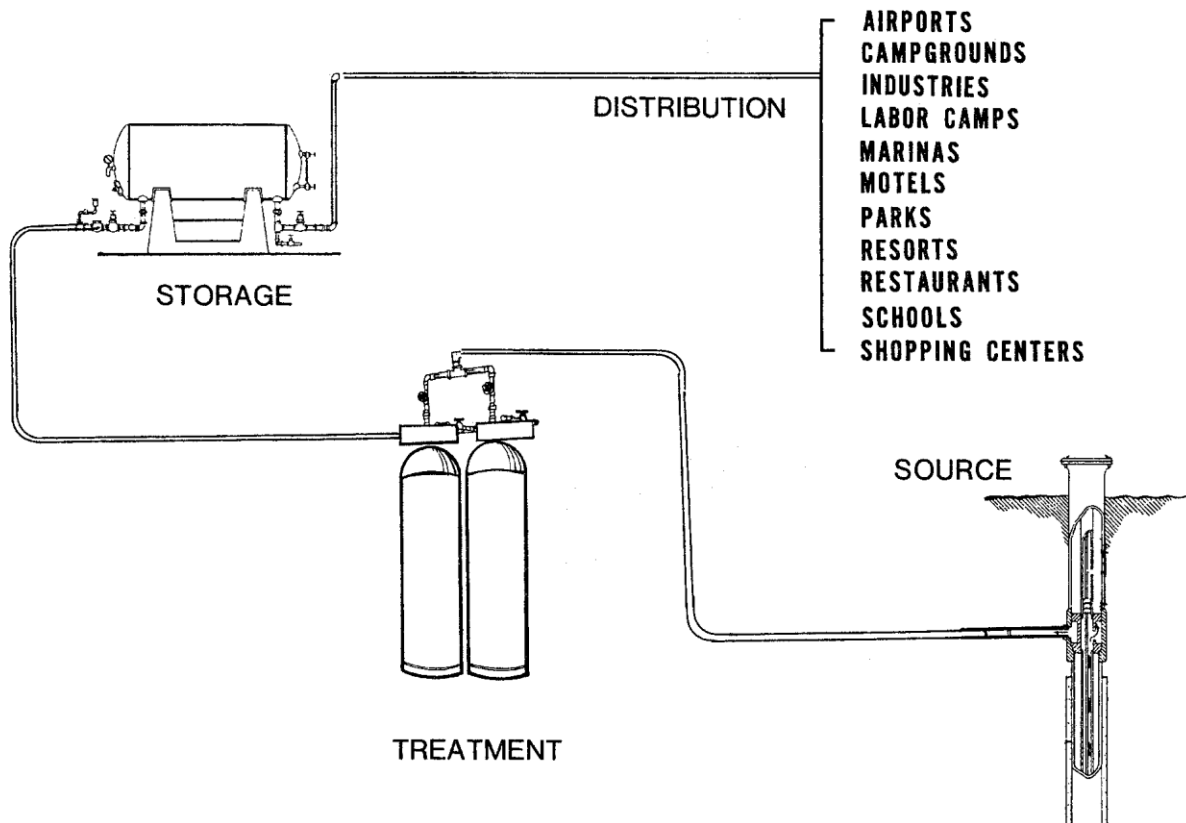

PART IV NONCOMMUNITY SYSTEM DESIGN STANDARDS

DEPARTMENT OF ENVIRONMENTAL PROTECTION
Bureau of Water Standards and Facility Regulation

DOCUMENT NUMBER: 383-2128-108

TITLE: Public Water Supply Manual - Part IV
Noncommunity System Design Standards

EFFECTIVE DATE: March 2, 1998
Minor revisions were made to pages i, iv, and 8 (April 1, 1999).
Minor revisions were made to pages i, 4, 8 and 29 (November 8, 2000).
Minor revisions were made to page i, vi, vii, 4 and 8 (May 21, 2001).

AUTHORITY: Pennsylvania's Safe Drinking Water Act (35 P.S. §721.1 *et seq.*) and regulations at 25 Pa. Code Chapter 109

POLICY: Department of Environmental Protection (DEP) staff will follow the guidance and procedures presented in this document to direct and support implementation of permitting activities for noncommunity water systems under the drinking water management programs.

PURPOSE: The purpose of this document is to establish a rational and reasonable basis for staff decisions which will promote quality, timely and consistent service to the public and regulated community.

APPLICABILITY: This guidance will apply to all noncommunity water systems.

DISCLAIMER: The policies and procedures outlined in this guidance document are intended to supplement existing requirements. Nothing in the policies or procedures shall affect regulatory requirements.

The policies and procedures herein are not an adjudication or a regulation. There is no intent on the part of the Department to give these rules that weight or deference. This document establishes the framework, within which DEP will exercise its administrative discretion in the future. DEP reserves the discretion to deviate from this policy statement if circumstances warrant.

PAGE LENGTH: 41 pages

DEFINITIONS: See 25 Pa. Code Chapter 109

PUBLIC WATER SUPPLY MANUAL USER'S GUIDE

The Public Water Supply Manual is a comprehensive publication designed to provide necessary, useful information to public water suppliers concerning Pennsylvania's Safe Drinking Water Program administered by the Department of Environmental Protection (DEP). The manual contains essentially everything the public water supplier will need to know about the Safe Drinking Water Program, including: design and construction standards; water quality standards; monitoring, reporting and operating requirements; emergency measures; and information on government agency programs and contacts.

Technical guidance documents are on DEP's world wide website (www.depweb.state.pa.us) the public participation center.

The "Final Documents" heading is the link to a menu of the various DEP bureaus and from there to each bureau's final technical guidance documents.

The "Draft Technical Guidance" heading is the link to DEP's draft technical guidance documents.

DEP encourages the use of the internet to view guidance documents. When this option is not available, persons can order a bound paper copy of the latest inventory or an unbound paper copy of any of the final documents listed on the inventory by calling DEP at (717) 783-3795.

The following is a summary of the Public Water Supply Manual Parts. Following the summary is a Table of Contents for each part in the Public Water Supply Manual.

Part I - Summaries of Key Requirements

Part I is no longer published as a compilation of all the summaries of key requirements. The summaries of key requirements are available as individual documents. Additional summaries are added as new rules and regulations are adopted.

Part II - Community System Design Standards

Part II provides detailed design and construction standards for all community water systems except bottled water systems, bulk water haulers, vended water systems and retail water facilities. Part II also contains instructions for submitting a public water system permit application.

Part III - Bottled Water, Bulk Water Hauling, Water Vending Machines and Retail Water Facilities

Part III provides detailed design and construction standards for bottled water systems, bulk water haulers, vended water systems and retail water facilities including information on submitting a public water system permit application.

Part IV - Noncommunity System Design Standards

Part IV provides detailed design and construction standards for noncommunity water systems, including information on the procedures to be followed to obtain DEP's approval.

Part V - Operations and Maintenance

Part V provides the needed information to develop an Operations and Maintenance Plan as required under Section 109.702 of DEP's Safe Drinking Water Regulations. This is a comprehensive guidance document covering all aspects of public water system operations including operation and maintenance standards.

Part V has been developed as two separate documents. Each is designed for specific type systems:

- Sections I and II is for surface water systems and the larger groundwater systems.
- Appendix A, Operations and Maintenance for Small Groundwater Systems, is a condensed version containing information needed by small groundwater systems having limited treatment (disinfection and corrosion control).

Part VI - Emergency Response

Part VI discusses the measures which a water supplier should take to prepare for emergency circumstances and explains how to prepare an emergency response plan.

Part VII - Cross-connection Control/Backflow Prevention

Part VII provides the basic information needed by a public water supplier to establish an effective cross-connection control program.

**PUBLIC WATER SUPPLY MANUAL
TABLE OF CONTENTS**

PART I SUMMARIES OF KEY REQUIREMENTS

Community Water Systems
Nontransient Noncommunity Water Systems
Transient Noncommunity Water Systems
Bottled Water Systems
Vended Water Systems, Retail Water Facilities, and Bulk Water Hauling Systems
Lead and Copper Rule
Phase II and Phase V/Wellhead Protection Rule
Surface Water Filtration Rule
Surface Water Identification Protocol
Total Coliform Rule
Consecutive Water Systems

PART II COMMUNITY SYSTEM DESIGN STANDARDS

Chapter 1 Applications for Permits
Chapter 2 Preliminary Design Considerations
Chapter 3 Source Development and Construction
Chapter 4 Treatment
Chapter 5 Chemicals and Chemical Handling
Chapter 6 Pumping Facilities
Chapter 7 Finished Water Storage
Chapter 8 Distribution Systems

**PART III BOTTLED WATER, BULK WATER HAULING, WATER VENDING
MACHINES AND RETAIL WATER FACILITIES**

Chapter 1 Applications for Permits
Chapter 2 Bottled Water Systems
Chapter 3 Bulk Water Hauling Systems
Chapter 4 Vended Water Systems
Chapter 5 Retail Water Facilities
Appendix A Operation and Maintenance Standards

PART IV NONCOMMUNITY SYSTEM DESIGN STANDARDS

Chapter 1 Applications for Permits
Chapter 2 Sources
Chapter 3 Treatment
Chapter 4 Chemical Handling and Feeding
Chapter 5 Finished Water Storage
Chapter 6 Pumping Equipment
Chapter 7 Distribution Systems

PART V OPERATIONS AND MAINTENANCE (SECTIONS I & II)

SECTION I PREPARATION OF O & M PLAN

- Chapter 1 Description of Facilities
- Chapter 2 Start-up and Normal Operating Procedures
- Chapter 3 Planned Maintenance Program
- Chapter 4 Records and Reporting System
- Chapter 5 Sampling and Analysis Program and Compliance Monitoring
- Chapter 6 Public Notification
- Chapter 7 Staffing and Training
- Chapter 8 Sanitary Survey Program
- Chapter 9 Safety Program
- Chapter 10 Emergency Plan and Operating Procedures

SECTION II OPERATION AND MAINTENANCE PROCEDURES

- Chapter 1 Sources of Supply
- Chapter 2 Treatment
- Chapter 3 Distribution
- Chapter 4 Laboratory Equipment Maintenance

Appendix A Operations and Maintenance for Small Groundwater Systems

PART VI EMERGENCY RESPONSE

- Chapter 1 Characteristics of Emergency Conditions and General Protection Measures
- Chapter 2 Hazard Analysis and Vulnerability Assessment
- Chapter 3 Developing Emergency Response Plans
- Appendix A Example Emergency Response Plan

PART VII CROSS-CONNECTION CONTROL/BACKFLOW PREVENTION

- Chapter 1 Definitions
- Chapter 2 Cross-connection Control Program
- Chapter 3 Recommended Cross-connection Control and Backflow Prevention Devices
- Chapter 4 Model of an Ordinance for the Control of Backflow and Cross-Connections

PART IV

NONCOMMUNITY DESIGN STANDARDS

	Page
Introduction.....	IV-1
CHAPTER 1 - APPLICATIONS FOR PERMITS.....	IV-2
1.0 General.....	IV-2
1.1 Scope.....	IV-2
1.2 Permit Requirements.....	IV-2
1.3 Submission of Applications	IV-3
1.3.1 Systems Approved Under the Above Regulations.....	IV-4
1.3.2 Systems Not Covered Under Other Regulations	IV-4
1.4 Design Considerations	IV-5
1.5 Water Volume Requirements.....	IV-5
1.6 Sources of Water.....	IV-5
1.6.1 Analyses of Proposed Sources	IV-5
1.7 Chemicals and Materials.....	IV-7
1.8 Physical Connection.....	IV-7
TABLE IV-1.1 DEP Regional Offices.....	IV-8
TABLE IV-1.2 Minimum Water Requirements.....	IV-9
CHAPTER 2 - SOURCES.....	IV-10
2.0 General Construction Requirements for Wells.....	IV-10
2.1 Wellhead	IV-10
2.2 Pitless Adaptors	IV-11
2.3 Well Casing.....	IV-11
2.4 Well Screens	IV-11
2.5 Minimum Distances	IV-11
2.6 Disinfection of Wells	IV-12
2.6.1 Recommended Procedure	IV-12
2.7 Springs	IV-13
2.8 Cisterns	IV-15
2.9 Surface Water.....	IV-15
CHAPTER 3 - TREATMENT.....	IV-16
3.0 General.....	IV-16
3.1 Chlorination	IV-16
3.1.1 Equipment.....	IV-16
3.1.2 Chlorine Solution	IV-17
3.1.3 Installation	IV-17
3.1.4 Tablet Chlorinators	IV-17

3.2	Ultraviolet Irradiation (UV).....	IV-21
3.2.1	Materials	IV-21
3.2.2	Design Criteria	IV-21
3.2.3	Installation.....	IV-23
3.3	Cartridge Filtration.....	IV-23
3.3.1	Materials	IV-23
3.3.2	Design	IV-23
3.3.3	Installation.....	IV-25
CHAPTER 4 - CHEMICAL HANDLING AND FEEDING		IV-26
4.0	General.....	IV-26
4.1	Feeding Equipment	IV-26
4.2	Solution Tanks	IV-26
4.3	Chemical Feed Lines.....	IV-26
4.4	Handling of Chemicals	IV-26
4.5	Operator Safety	IV-27
CHAPTER 5 - FINISHED WATER STORAGE.....		IV-28
5.0	General.....	IV-28
5.1	Elevated or Standpipe Storage	IV-28
5.1.1	Standards.....	IV-28
5.1.2	Design Criteria	IV-29
5.2	Hydropneumatic Storage	IV-29
5.2.1	Design and Installation	IV-29
5.3	Ground Level Storage.....	IV-30
5.3.1	Design and Installation	IV-30
5.3.2	Standards - Fiber Glass Tanks	IV-31
CHAPTER 6 - PUMPING EQUIPMENT		IV-32
6.0	General Design.....	IV-32
6.1	Location	IV-32
6.2	Pump Controls	IV-32
CHAPTER 7 - DISTRIBUTION SYSTEMS		IV-33
7.0	General Requirements.....	IV-33

PART IV

NONCOMMUNITY DESIGN STANDARDS

Introduction

DEP recognizes that most of the public water supply design requirements outlined in Part II (Community System Design Standards) of this manual do not apply to the smaller noncommunity type water systems. Nor does Part II provide appropriate information on water treatment processes which have been commonly used by noncommunity water supply systems in the past. The purpose of Part IV is to provide design information on those processes which DEP finds satisfactory for use by noncommunity water suppliers. The design requirements already established in Part II should be utilized where applicable.

Proposals to use surface water sources will require the submission of a complete permit application as outlined in Section 109.503 of DEP's Safe Drinking Water Regulations (25 Pa. Code Chapter 109). Part II of this manual should be referenced for details concerning permitting requirements for surface water sources.

PART IV

CHAPTER 1 - APPLICATIONS FOR PERMITS

1.0 General

The purpose of this chapter is to outline the design considerations and permit application procedures which are to be followed by noncommunity water supply systems. This information has been taken, in part, from guidelines published by member states of the Great Lakes-Upper Mississippi River Board (10 states), the Conference of State Sanitary Engineers and technical guidelines published by the water supply industry. Alternative designs may be approved by DEP if it can be demonstrated that they will be capable of providing a consistently reliable, safe quality of drinking water to the public.

1.1 Scope

DEP's Safe Drinking Water Regulations define a public water system as, "A system which provides water to the public for human consumption which has at least 15 service connections or regularly serves an average of at least 25 individuals daily at least 60 days out of the year." The regulations further categorize public water supply systems into two types: (1) Community systems which serve *year around* residents, and (2) Noncommunity systems which serve *transient and nontransient* public.

A *transient noncommunity* water system (TNCWS) is a noncommunity water system which serves a transient population.

A *nontransient noncommunity* water system (NTNCWS) is a noncommunity water system that regularly serves at least 25 of the same persons over six months per year.

Examples of noncommunity water systems which must comply with the regulations and Part IV are:

Transient	Nontransient
Shopping Centers	Schools
Highway Rest Areas	Industries
Motels-Hotels-Resort Areas	Workplaces
Swimming Pools/Beaches	Hospitals
Airports	Day Care Centers
Campgrounds	
Churches	
Parks and Restaurants	

1.2 Permit Requirements

Section 109.505 of the Safe Drinking Water Regulations contains the specific permit requirements for noncommunity water systems. Most noncommunity water systems are not required to obtain a public water supply permit if they satisfy the requirements of Sections (1) or (2) of 109.505 as outlined below.

- 1) The noncommunity water system is issued a license or permit from one of the following Commonwealth Agencies under the specified Act:
 - i) Department of Agriculture - An Eating and Drinking Place License as issued under the Act of May 23, 1945 (P.L. 926, No. 369) (35 P.S. 65.5.1 – 655.13);
 - ii) Department of Agriculture - A Seasonal Farm Labor Camp Permit as issued under the Seasonal Farm Labor Act (43 P.S. 1301.101 – 1301.606);
 - iii) Department of Health - A Public Bathing Place Permit as issued under the Public Bathing Law (35 P.S. 672 – 680d).

Noncommunity water systems regulated under these acts will have their water supply systems reviewed as part of the respective licensing/permitting process (see Section 1.3.1).

- 2) The noncommunity system uses a groundwater source (see Note 1) which requires treatment no greater than disinfection (see Note 2) to meet DEP's drinking water standards.

Note 1: Under Section 109.202 any public water system (including noncommunity systems) which propose the use of a surface water source must provide filtration and disinfection and are required to obtain a public water supply permit as outlined in Section 109.503 of the regulations. Applicants should refer to Part II of the Public Water Supply Manual, "Community System Design Standards" for specific requirements.

Note 2: Noncommunity water systems which must provide treatment greater than simple disinfection to meet DEP's primary maximum contaminant levels are required to obtain a public water supply permit as outlined in Section 109.503 of the regulations. Applicants should refer to Part II of the Public Water Supply Manual, "Community System Design Standards" for specific requirements.

1.3 Submission of Applications

Within DEP, the Bureau of Water Supply and Wastewater Management administers the Safe Drinking Water Regulations. The bureau also coordinates the review of water supply systems with the Department of Agriculture and the Department of Health in accordance with the following regulations adopted under their respective acts listed in 1.2 above:

- a) The Food Establishment Regulations (Chapter 151);
- b) The Seasonal Farm Labor Regulations (Chapter 177);
- c) The Public Swimming and Bathing Place Regulations (Chapter 193).

The following procedures should be utilized when making application for a license or a permit as a noncommunity water system.

1.3.1 Systems Approved Under the Above Regulations

Noncommunity systems in this category will have their water supply facilities evaluated and approved as part of the review process used in issuing licenses or permits under the above regulations. In addition to submitting the documents required under each of the above specific programs, applicants must submit an analysis of the raw water. For transient noncommunity water systems, the evaluation shall include Nitrate (as nitrogen) and Nitrite (as nitrogen); total coliform concentration and, if total coliform-positive, analyze for fecal coliform concentration; and any other contaminant which DEP determines is necessary to evaluate the potability of the source. For nontransient noncommunity water systems, the evaluation shall include a complete analysis as detailed in Section 109.503(a)(1)(iii)(B) of the SDWA regulations. The applicant also must contact their regional office (see Table IV-1.1) for information and assistance on completing a PWS Inventory and Brief Description Form (3800-FM-WSWM0033) (Safe Drinking Water Program Staff Handbook Field Manual – Tab 5, Section I) and for the current list of contaminants to be tested.

1.3.2 Systems Not Covered Under Other Regulations

A noncommunity water system not covered under one of the acts outlined in section 1.2.1 above is not required to obtain a construction and all operation permit if it satisfies the following specifications and conditions:

- (i) The sources of supply for the system are groundwater sources requiring treatment no greater than disinfection to provide water of a quality that meets the primary MCLs established under Subchapter B (relating to MCLs or treatment technique requirements).
- (ii) The water supplier files a brief description of the system, including raw source quality data, on forms acceptable to DEP. Amendments to the system description shall be filed when a substantial modification is made to the system. Descriptions of the new systems or modifications may be filed prior to construction if the water supplier desires technical assistance, but shall be filed within 30 days of initiation of operation of the system or modification.

Noncommunity water systems meeting these specifications and conditions must submit an analysis of the raw water in accordance with the requirements detailed in section 1.3.1 above unless the new source is finished water obtained from an existing permitted community water system or an existing permitted or approved noncommunity water system.

1.4 Design Considerations

The following design considerations shall be evaluated when considering a potable water system for a noncommunity water supplier:

- a. If an adjacent public water system is available and if connection can reasonably be made thereto;
- b. The dependability of the source of water supply;
- c. Raw water quality;
- d. Potential and known sources of contamination;
- e. A balanced system of supply, pumping, treatment, distribution and finished water storage facilities to meet the peak demand;

1.5 Water Volume Requirements

Noncommunity water supply systems shall be designed to provide at least the minimum quantity of potable water as determined from Table IV-1.2, and with a minimum flow rate of two gallons per minute at each outlet or plumbing fixture.

1.6 Sources of Water

The source of water should be derived from wells. The use of springs and surface water may be used only where the appropriate level of treatment is approved by DEP. Duplicate wells and pumping equipment or equivalent should be provided when the average water demand exceeds 30,000 gallons per day.

1.6.1 Analyses of Proposed Sources

As a minimum, all new sources of drinking water must be sampled and tested. Contact the appropriate regional office listed in Table IV-1.1 for the current list of contaminants to be tested. Other parameters which a sanitary survey may determine as having a potentially adverse impact on the quality of the raw water should also be included in the analyses so that background information for future comparison is available.

1.6.1.1 Laboratories

All analyses of proposed sources must be performed by a DEP certified laboratory.

1.6.1.2 Surface Water Sources

At least three sets of samples spaced so that the high, average and low stream flows will be sampled shall be taken to reflect the effects of various meteorological, geological and hydrological conditions. Samples shall be taken during a minimum time interval of six months and preferably one year.

1.6.1.3 Groundwater Sources

A pumping test should be conducted to characterize water quality and determine that a sufficient quantity of water is available to meet the intended use of the well. A pumping test provides a cursory assessment of a single well and is distinguished from an aquifer test in which the hydraulic properties of an aquifer are derived from drawdown data collected over an extended period of time.

The pumping test shall be at a constant withdrawal rate not less than the proposed rate. It is recommended that the following information be obtained from the pumping test:

- a. Date and time of all static, pumping, and recovery water level measurements.
- b. Record of pumping rate measured frequently throughout the test.
- c. Sufficient static water level measurements in all wells to determine any trends in water level changes prior to the beginning of pumping.
- d. Pumping and recovery measurements from the pumped well.
- e. Monitoring data from a sufficient number of wells to determine all possible interference.
- f. Records of precipitation, measurements or observations of nearby streamflows, and weather conditions throughout the test.

For transient non-community water systems (TNCWS) a minimum 6 hour pumping test should be conducted on the basis that most TNCWS will conduct the majority of their business during the three meal periods. A 6 hour pumping test therefore takes into consideration 1 hour for each meal period with a 1 hour safety factor as well.

Non-transient non-community water systems (NTNCWS) shall conduct a minimum 12 hour and maximum 24 hour pumping test on the basis that NTNCWSs will be providing water during a school day or 8 hour work shift.

At least one set of samples for evaluation in accordance with Section 1.3.1 shall be collected at the termination of the pumping test. Applicants should notify DEP at least 48 hours prior to starting the pumping test. Applicants are further advised to contact their respective river basin commission to verify the need to conduct a longer (i.e., 72-hour) pumping test or an aquifer test.

1.6.1.4 Finished Water Sources

At least one set of samples shall be collected and tested for all the parameters to be determined by DEP. Contact the appropriate regional office for the current list of parameters to be tested. The results of analysis obtained by the source/selling water system may be used to satisfy this requirement provided the samples were collected and analyzed within the routine monitoring schedule for that category of parameters. The results submitted should be from samples collected as close to the proposed point of interconnection as is possible, and preferably from the exact location.

1.7 Chemicals and Materials

No chemicals shall be applied to drinking waters unless specifically permitted by DEP. Chemicals which may come in contact with or affect the quality of the water and which are certified for conformance with ANSI/NSF Standard 60 (Drinking Water Treatment Chemicals-Health Effects) or meet the food grade standards of the United States Pharmacopeia are acceptable to DEP.

Materials used in the construction or modification of a public water system including waterline extensions which may come into contact with or affect the quality of the water and which are certified for conformance with ANSI/NSF Standard 61 (Drinking Water System Components – Health Effects – National Sanitation Foundation) are deemed acceptable to the Department.

1.8 Physical Connection

No physical connection shall be established between any noncommunity water supply system installed in accordance with these standards and a community water supply system unless the physical connection is in accordance with the provisions of Part VII (Cross-Connection Control/Backflow Prevention) of this manual.

TABLE IV-1.1
DEP REGIONAL OFFICES

- The completed form is to be addressed to: PA DEP - Safe Drinking Water and sent to the address of the appropriate district office or county health department (CHD) having jurisdiction over the water system.

- District and CHD addresses by county can be found within DEP document number 3930-FM-BSDW0560. This document can be located by searching under “forms” for document number 3930-FM-BSDW0560 on eLibrary at the following link:
<http://www.depgreenport.state.pa.us/elibrary/GetFolder?FolderID=3195>.

**TABLE IV-1.2
MINIMUM WATER REQUIREMENTS**

<u>Type of Establishment</u>	<u>Gallons per Person per Day</u>
1. Boarding houses**	75
a. For each nonresident boarder	15
2. Campgrounds	
a. Where individual sewer hookups are available	100 per site
b. Without individual sewer hookups	50
3. Camps	
a. Summer	50
b. Day camps (no meals served)	15
4. Cottages (seasonal)	50
5. Hotels**	50-75
6. Laundries (self service)	50 gal/wash
7. Motels and tourist cabins	
a. With bath, toilet and kitchen facilities	75
b. With bath and toilet	50
8. Picnic grounds and comfort stations	
a. With toilet facilities only	10
b. With bathhouses, showers and flush toilets	25
9. Restaurants	
a. With public toilets	7-10
b. Without public toilets	3
c. With bar or cocktail lounge, additional	2
10. Schools	
a. Boarding	75-100
b. Day, without cafeteria or showers	10
c. Day, with cafeteria and no showers	15
d. Day, with cafeteria and showers	30
11. Shopping centers (per 1,000 ft ² floor area)	250
12. Stores (per toilet room)	400

* When more than one use will occur, the multiple use shall be considered in determining water quality.

** Includes kitchen demand @ 10 gallons per person per day. If laundry demands are anticipated, estimated flows should be increased by 50 percent.

PART IV

CHAPTER 2 - SOURCES

2.0 General Construction Requirements for Wells

- a. In accordance with Section 109.604(b) of the Safe Drinking Water regulations all new sources shall be located to prevent or minimize impacts from existing potential sources of contamination and causes of diminution.
- b. The actual on-site work of drilling, constructing, altering, and repairing a well shall be under the supervision of a person in possession of a valid well drillers license issued by DCNR's Bureau of Topographic and Geologic Survey, preferably a certified well driller.
- c. During construction, the area surrounding the well shall be maintained in a clean condition and surface drainage shall be diverted away from the well.
- d. All wells shall be cased and grouted to protect against contamination. Water bearing formations that are known to be contaminated or those identified by DEP as being in danger of contamination shall be sealed off with grout. Sealing shall be accomplished by a method approved by DEP.
- e. Prior to final completion of the well, the casing should be capped and any open annular space covered until the well has been grouted and the pump installed. The cap should be either threaded onto the casing or be a friction type device which locks onto the outside of the casing.
- f. After construction of the well it should be properly developed to obtain the best practical yield and quality. Testing of the well should be conducted as outlined in the current American Water Works Association's Standard on Water Wells.
- g. Unsuitable or nonproductive wells shall be sealed in accordance with the requirements of DEP.

2.1 Wellhead

- a. The wellhead shall be constructed to assure the maximum protection of the well, and to exclude entry of any contaminant.
- b. When the casing is brought above grade or is located in an offset basement pump room, the top of the well casing shall be located not less than 18 inches above grade or basement floor.
- c. Whenever possible the pump shall be located and designed to make the use of a pump pit unnecessary. Under extenuating circumstances, pump pits may be accepted on condition that adequate provision is made for their drainage by a sump pump or other arrangement. Direct connections to a sanitary sewer or storm drain shall not be made.
- d. The wellhead shall be provided with either a pitless installation or a sanitary seal.

- e. The space between the pump column and the casing of each well shall be provided with a vent which shall be protected with a down-facing elbow or mushroom-type head located at least 36 inches above flood levels. All vents shall be screened against the entry of insects.
- f. Wells in which pumping equipment is not installed shall be properly capped to exclude the entry of contamination pending such installations.

2.2 Pitless Adaptors

Where used, pitless adaptors shall conform with the standards set forth in the American Water Works Association’s Standard on Water Wells.

2.3 Well Casing

Well casing shall conform to the standards outlined in the American Water Works Association’s Standard on Water Wells.

2.4 Well Screens

A well screen should be provided where necessary to insure delivery of water which shall be visibly free from sand and/or silt.

2.5 Minimum Distances

DEP should be consulted prior to design and construction regarding a proposed well location as it relates to required separation between existing and potential sources of contamination.

Minimum distances from a well to possible sources of pollution shall be great enough to provide assurances that subsurface flow of contaminated water will not reach the well. Each proposed site should be field surveyed to evaluate the character and location of possible sources of contamination, types of geologic formations present, depth to the water bearing aquifer, direction of groundwater flow and the effect on groundwater movement by well pumping.

The **following minimum lateral distances shall apply for clay and loam soils.** However, the distances are to be increased for areas where more pervious soils, such as sand and gravel, are found.

<u>Source of Pollution</u>	<u>Separation Distance “ft”</u>
Cesspools	100
Septic Tanks	50
Drain Field	100
Sewers - (Non-Cast Iron)	50
Sewers - (Cast Iron Pipe with Leaded or Mechanical Joints)	10

2.6 Disinfection of Wells

All wells serving noncommunity water systems are to be properly disinfected by chlorination before being placed into service or after work is done on the well or pump that could contaminate the water source. The following procedure outlines a common method of well disinfection.

2.6.1 Recommended Procedure

1. Remove any cover over the well casing to allow access to the water source.
2. Add the appropriate amount of approved chlorinating compound (see below) to three or four bucketsful of water (six to 10 gallons total) and mix thoroughly.
 - a. For liquid chlorinating products with five to six percent available chlorinating chemical, use about 1 1/2 quarts of the chlorinating product.
 - b. For liquid chlorinating products with more available chlorinating chemical, reduce the amount used. For example, for products with 10 percent use about 3/4 quart or for products with 14 percent use about 1/2 quart of the chlorinating chemical.
 - c. For granular chlorinating chemicals with 65 to 70 percent available chlorinating chemical, use about four ounces (10 tablespoons) of the chlorinating product.

The process of mixing the appropriate amount of chlorinating product with six to 10 gallons of water is important for the following reasons:

- a. It helps to mix the disinfectant evenly through the water in the well and force the disinfectant into the surrounding water-bearing rocks.
 - b. It prevents the concentrated chlorinating chemical from corroding the metal pump and other metal parts of the well.
3. These amounts of chlorinating products will disinfect about 150 gallons of water to 100 – 150 parts per million (ppm). That corresponds to 100 feet of water in a six-inch diameter well. If your well holds more or less water, the amount of chlorinating product should be increased or decreased proportionately.
 4. Place one end of the garden hose into the well so that the hose is as far into the well as possible.
 5. Place the funnel into the other end of the hose and, with help, pour the contents of each bucketful of diluted chlorinating product through the hose while alternately raising and lowering the hose to disperse the disinfectant throughout the water supply.

6. When the appropriate amount of disinfectant has been added to the water supply, do the following:
 - a. Draw the chlorinated water through all the fixtures and outlets until the smell of chlorine is noticed, so that all of the piping and fixtures are disinfected. After the odor is noticed, turn off the water at the fixture or valve outlet.
 - b. In some cases involving wells, running the water from fixtures may not produce a chlorine odor quickly; in those cases, it may be necessary to run the water from an outside faucet through a garden hose and back into the well to further mix the chlorinating chemical into the well water.
7. The chlorinating solution should remain in the entire water supply system for at least four hours and preferably overnight. The water should be pumped out after that period until no odor of chlorine remains at the fixtures and outlets.
8. Once the water source is chlorine-free, a bacteriological sample should be collected for analysis. If total coliform organisms are present, the water should not be consumed unless it is brought to a rolling boil for at least one minute. If total coliform organisms are not found, the source water is considered bacteriologically potable. However, the raw well water should be sampled for bacteria at least annually, even if a disinfection device is in use to treat for bacterial contamination.
9. If the well or spring continues to be contaminated after disinfection and sampling or is found to be contaminated as the result of a future sample, the construction or location of the water supply should be re-evaluated.
10. Wells with bacteriological contamination may require the installation of continuous disinfection equipment and storage to provide contact time. Disinfecting a well may be used if the source of the contamination is temporary, such as may occur when a well is opened for repairs.
11. Routine compliance monitoring of the water is required at the tap. The summary of key requirements for transient and nontransient noncommunity water systems should be referenced for compliance monitoring details.

2.7 Springs

The use of springs should be avoided as the quantity of water can be subject to seasonal fluctuations and the quality is vulnerable to contamination due to the typically shallow depth to water. Where the use of a spring cannot be avoided, the applicant should refer to Part II of the Public Water Supply Manual, "Community System Design Standards" for details concerning permitting requirements for surface water sources.

Springs and other high risk sources also require additional testing under the Surface Water Identification Protocol (SWIP) to determine the susceptibility of the source to the direct influence of surface water. The applicant should contact their district office for details regarding

this requirement. However, if a spring source is proposed, the diagram on page 15 illustrates a properly developed spring in accordance with the following criteria:

- a. Springs shall be provided with an encasement of concrete or other durable material to exclude contamination, but should be installed as not to restrict the flow of water into the encasement;
- b. The walls of the encasement shall be extended above the elevation of the surrounding ground to prevent the entrance of surface water and a removable cover shall be provided so the collecting compartment can be entered and cleaned;
- c. The encasement shall be provided with all overflow construction to prevent erosion of the till surrounding the structure. The overflow shall be constructed to prevent the entrance of rodents, and shall be downfacing;
- d. The joint between the encasement wall and any pipe passing through the wall shall be constructed and installed to prevent the entrance of surface water;
- e. A diversion ditch should be provided to prevent surface water from flowing into the collecting compartment.

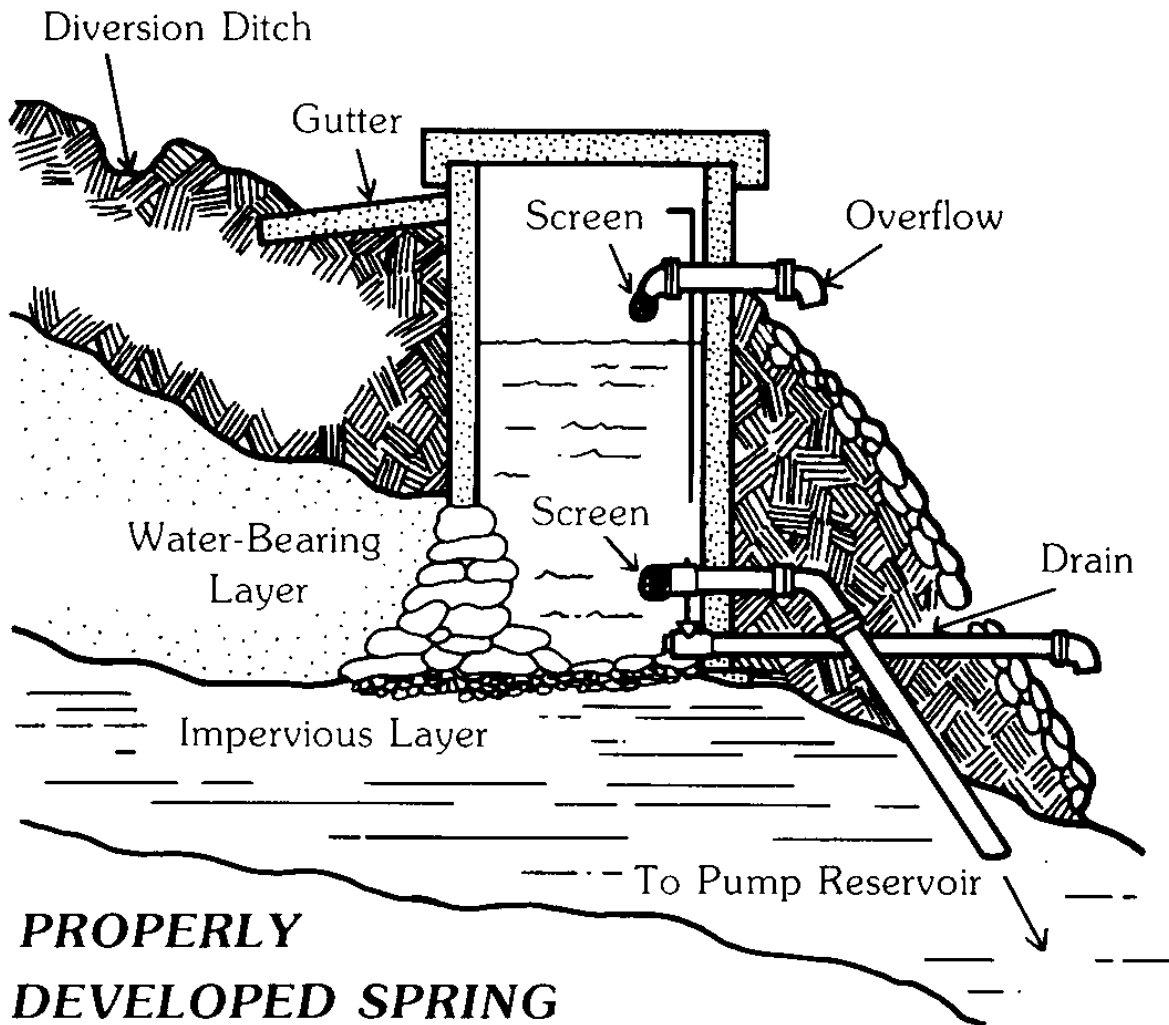

2.8 Cisterns

Cisterns are not considered acceptable as a source of potable water for noncommunity water supply systems. Where cisterns are used as finished water storage reservoirs the design standards in Chapter 5, Section 5.0, should be applied.

2.9 Surface Water

Surface water will not be accepted as a source of potable water for a noncommunity water system except with the specific approval of DEP and only when an alternate source of supply is unavailable. If a surface water source is proposed, adequate and continuously operating water treatment facilities will be required as outlined in Section 109.605(1) of DEP's Safe Drinking Water Regulations. Persons proposing the use of a surface water supply are required to obtain a public water system permit as outlined in Section 109.503 of the regulations.

Part II of the Public Water Supply Manual, "Community System Design Standards" should be referenced for details concerning permitting requirements for surface water sources.

PART IV

CHAPTER 3 - TREATMENT

3.0 General

Treatment is required when the quality of the untreated groundwater makes it unacceptable by DEP's standards and an alternate source of acceptable quality water is not available.

- a. Disinfection by chlorination is recommended for all noncommunity water systems and may be required to assure safe bacteriological quality.
- b. Ultraviolet light as a method of disinfection may be acceptable for noncommunity water supplies where the design is acceptable to DEP (see Section 3.2).
- c. Upon evaluation of the analysis of the source water, DEP will determine the need for additional treatment.
- d. A separate room or building should be used for water treatment, chemicals, and equipment and shall be accessible only to authorized personnel.

3.1 Chlorination

3.1.1 Equipment

- a. Hypochlorite feeders of the positive displacement type will be acceptable for all water systems to which these standards apply. Gas chlorinators of the solution feed type and tablet chlorinators may be utilized, but only with the specific approval of DEP.
- b. A minimum of 20-minutes contact time based on maximum pump capacity is to be provided.
- c. Where required, the chlorination facilities shall be capable of producing a chlorine residual after the contact period as proof of disinfection. A chlorine residual test kit shall be provided to insure that proper dosage is being maintained.
- d. Provision must be made to protect all equipment from freezing.
- e. If gas chlorination is used, all equipment shall be placed in above-grade separate rooms with outside entrance only and provided with suitable ventilation. An observation window to permit visual inspection without opening the door of the chlorine room shall be provided.
- f. If tablet chlorinators are used, the system shall be designed to operate under the slight vacuum created by the suction side of the pump or by gravity flow. PVC piping or tubing with solvent weld fittings is recommended.

- g. In the case of water derived from a well, operation of the chlorination facilities shall be synchronized with the operation of the well pump.

3.1.2 Chlorine Solution

Chlorine solution can be prepared by one of the following methods:

- a. Mix one gallon of a liquid chlorinating product with five to six percent available chlorinating chemical with five gallons of water in the solution tank. This will provide a solution of approximately one percent active chlorine (10,000 ppm). Three pints of commercial 15 percent sodium hypochlorite can also be used.
- b. Dissolve one-half pound of dry calcium hypochlorite (HTH, Pittchlor, etc.) into 4 1/2 gallons of water using a mixing tank. This will provide a solution of approximately one percent active chlorine. After the precipitate settles, the aqueous chlorine solution should be transferred to a solution tank for feeding to the system.

3.1.3 Installation

The installation of a hypochlorinator or a tablet chlorinator shall be such that it can only operate when the well pump operates. The injection point shall be before the pressure and retention tanks. If a softener is used, the injection point should be after the softener and before the pressure and retention tanks.

The pressure tank must be sized and designed to permit a full 20-minutes contact time or a separate retention tank must be provided. A pressure tank that is connected to the main line by a single pipe is considered as floating on the system. This cannot be considered as providing chlorine contact time.

The diagrams on pages 19 and 20 illustrate typical chlorination installations.

3.1.4 Tablet Chlorinators

- a. Plans showing the details of these installations and the location of the disinfection unit to an overall water supply system shall be submitted to and approved by DEP prior to construction.
- b. Tablet chlorinators shall be capable of producing a chlorine residual after the contact period as proof of disinfection.
- c. Chlorinator System:
 - 1. The untreated water coming into the chlorinator shall be controlled by a valve adjusted as necessary to consistently maintain the appropriate residual in the water system.

2. A “bypass” type chlorinator will be approved only when uniform flow is guaranteed by the water system design. Otherwise, a positive displacement feeder paced by the flow in the system will be required.

d. Installation

1. Chlorination shall be accomplished by passing a controlled portion of the water flow through a chlorinator containing calcium hypochlorite tablets.
2. The volume of calcium hypochlorite tablets in the chlorinator must be maintained at a level that insures constant contact with water flowing through the chlorinator.
3. The treated water shall have at least a 20 minute contact time and a minimum free or combined chlorine residual of not less than 0.2 mg/L. This may necessitate the addition of appropriately sized storage reservoirs after the treatment unit.

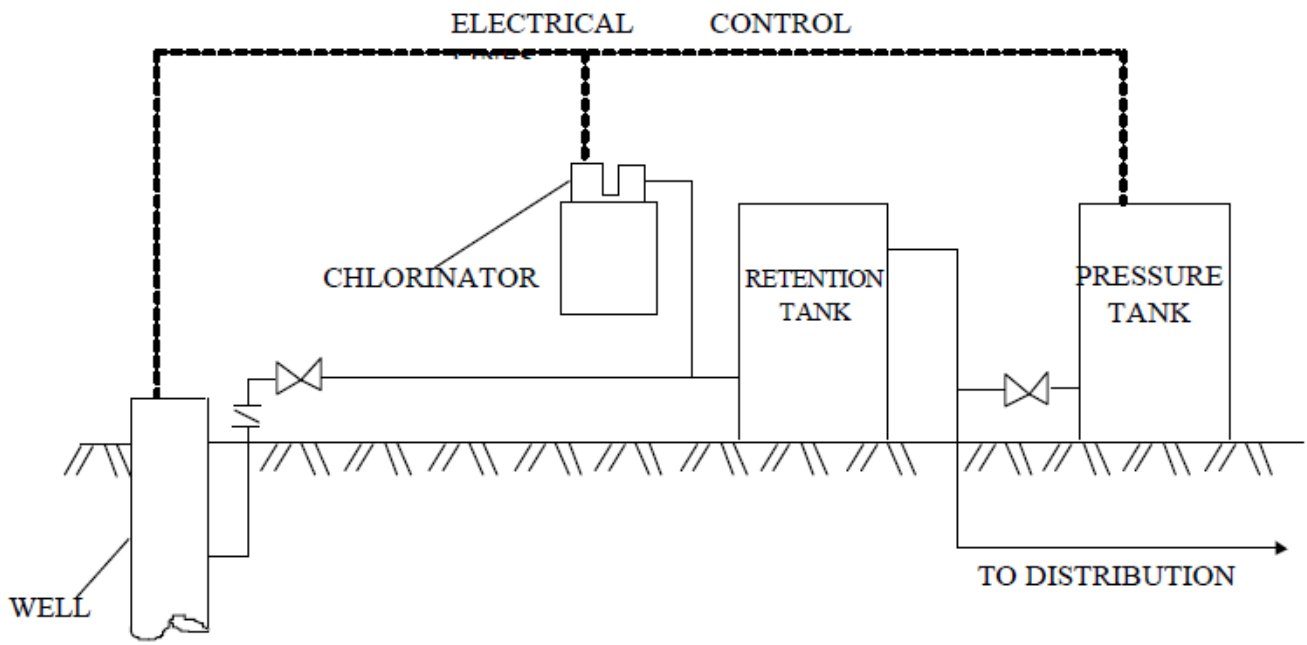

CHLORINATION ONLY

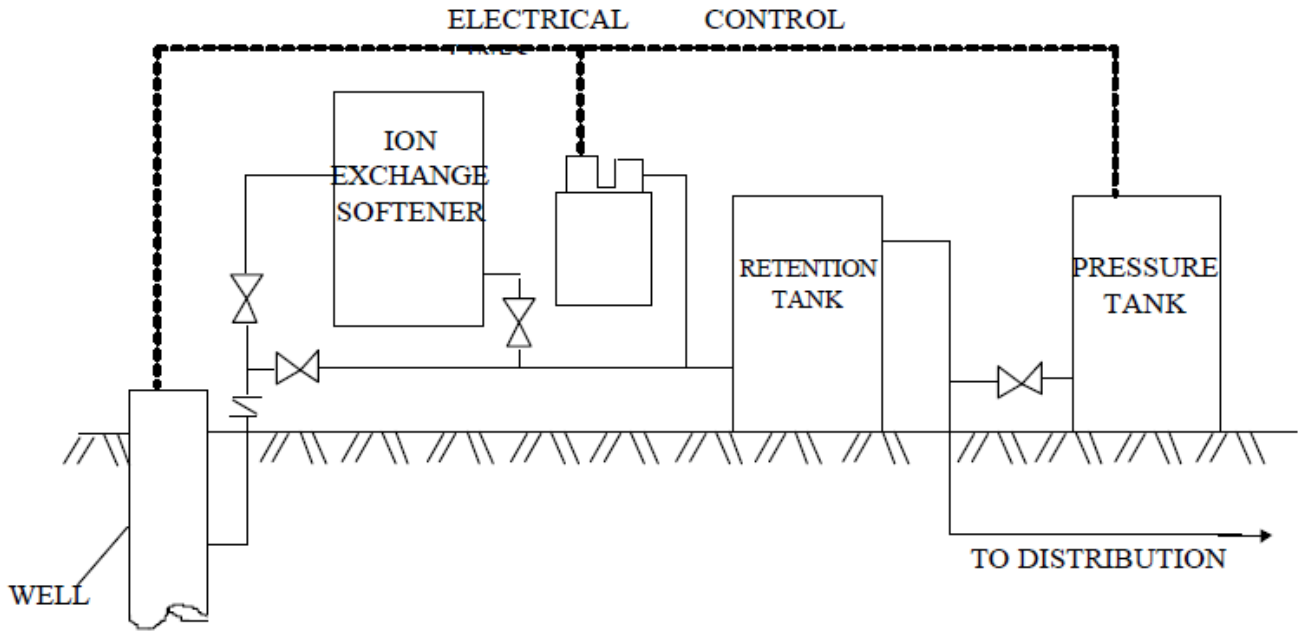

CHLORINATION WITH ION EXCHANGE SOFTENING

Tablet Chlorinator Diagrams

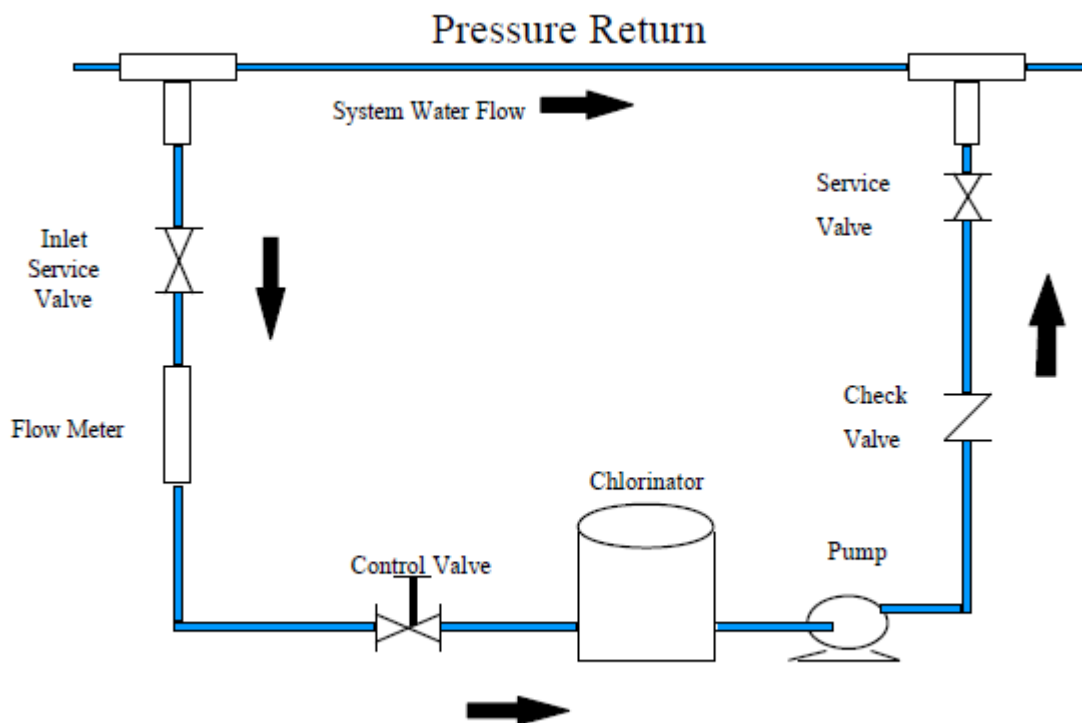
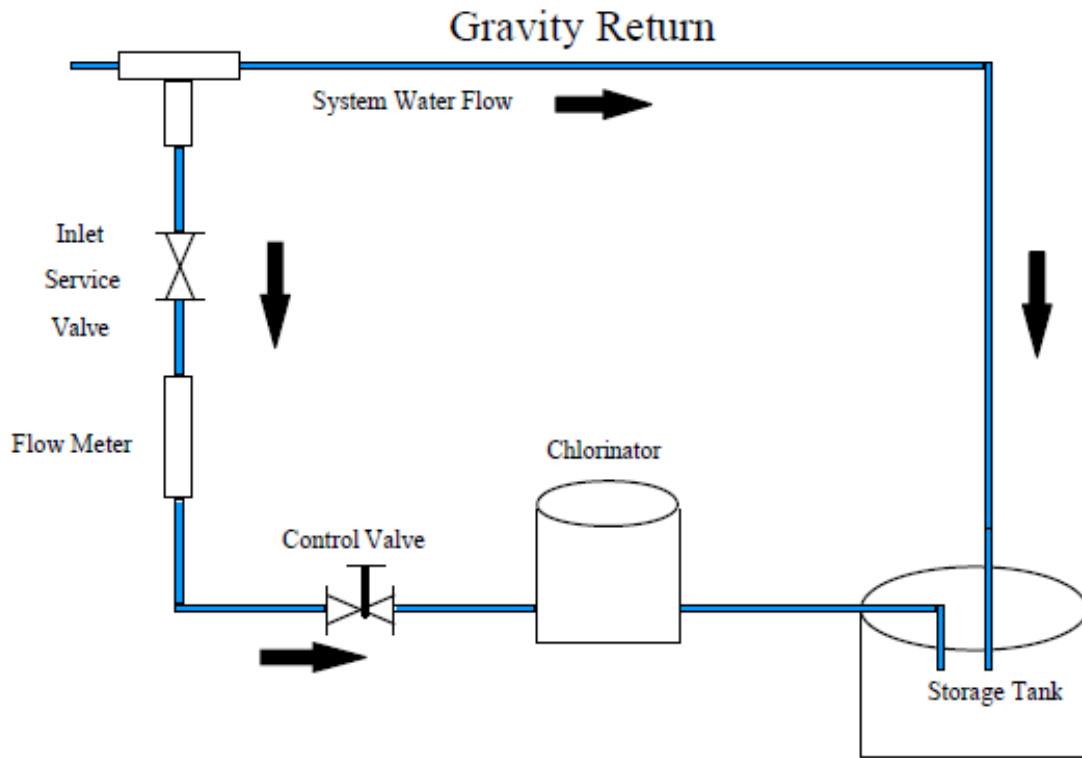

3.2 Ultraviolet Irradiation (UV)

Ultraviolet light produced by UV lamps has been shown to be an effective bactericide for certain pathogenic bacteria. However, DEP does not consider the use of UV acceptable for the inactivation of *Giardia lamblia* or *Cryptosporidium*. UV systems approved under the National Sanitation Foundation International (NSF) Standard 55 – Ultraviolet Water Treatment Systems are acceptable for use in drinking water disinfection.

Ultraviolet light disinfection will be considered only for small noncommunity water supplies and in certain special cases where other methods are not considered feasible. As ultraviolet treatment does not provide a residual disinfectant, it may only be used following all underground plumbing, and post-chlorination may be required to maintain safe water in the system.

UV system or component shall be designed and constructed so that its intended purpose shall be accomplished when installed and operated according to the manufacturers instructions. Components shall not be adversely affected by the normal environment to which they are subjected. Normal environment shall include usual vibration, shock, climate condition and cleaning procedures as prescribed by the manufacturer.

3.2.1 Materials

The materials in contact with water must not impart undesirable taste, odor, color, and/or toxic materials into the water as a result of the presence of toxic constituents in materials of construction or as a result of physical or chemical changes resulting from exposure from ultraviolet energy. Materials exposed to ultraviolet irradiation shall be formulated to resist deterioration and shall not impart undesirable tastes, odor, color, and/or toxic chemicals to the water upon irradiation.

Systems and/or components shall be constructed of materials suitable to withstand temperatures generated during sustained periods when the unit is not in use.

3.2.2 Design Criteria

The use of UV devices as a means of disinfection of public water supplies in Pennsylvania is acceptable provided the equipment used meets the design criteria described herein:

1. Ultraviolet radiation at a level of 2,537 Angstrom units must be applied at a minimum dosage of 16,000 microwatt-seconds per square centimeter at all points throughout the water disinfection chamber;
2. Maximum water depth in the chamber, measured from the tube surface to the chamber wall, shall not exceed 3 inches.
3. The UV system or component shall be provided with a visual means to verify electrical operation of lamps;

4. UV lamp assemblies shall be designed to be insulated from direct contact with the influent water. If the ultraviolet lamps or assemblies are intended to be replaced, they shall be removable;
5. The unit is to have an automatic flow control device, accurate within the expected range of operating pressures, so that the maximum design flow rate of the unit is not exceeded;
6. The systems and all components subject to line pressure shall be designed for a working pressure of at least 689 kPa (100 psig);
7. The system or component shall be designed to be accessible for cleaning and replacement of the lamp jackets and sensor window/lens which are provided on the systems. The manufacturers cleaning procedures shall result in thorough cleaning of the system. The treatment chamber shall be designed so that at least one end can be dismantled for cleaning;
8. The ultraviolet tubes must be:
 - a. Jacketed so that a proper operating tube temperature of about 105°F is maintained,
 - b. The jacket shall be of quartz or high silica glass with similar optical characteristics;
9. An accurately calibrated ultraviolet intensity meter, properly filtered to restrict its sensitivity to the disinfection chamber at the point of greatest water depth from the tube(s) shall be provided;
10. A flow diversion valve or automatic shut-off valve is to be installed which permits flow into the potable water system only when at least the minimum ultraviolet dosage is applied. When power is not being supplied to the unit, the valve should be in a closed (fail-safe) position which prevents the flow of water into the potable water system;
11. The unit must incorporate a device for monitoring or sensing ultraviolet transmission or intensity through the maximum depth of water in the chamber during operation. The monitoring or sensing device is to be installed that triggers an audible alarm in the event of lamp or sensor failure or if insufficient ultraviolet light reaches the sensor;
12. The unit must protect the operator against electrical shock or excessive ultraviolet energy;
13. If the operation of the ultraviolet light unit is synchronized with the operation of the well pump, a flow or time delay mechanism is to be provided to permit a two minute tube warm-up period before water flows from the unit.

3.2.3 Installation

1. The unit should be installed in a protected enclosure not subject to extremes of temperature which could cause malfunction.
2. Spare UV tubes and other necessary equipment are to be provided to effect prompt repair by qualified personnel properly instructed in the operation and maintenance of the equipment.
3. The unit is to be installed so as to allow ease of access for disassembly, repairs or replacement.

3.3 Cartridge Filtration

Cartridge filtration is being used more frequently for treatment of drinking water, and when used in conjunction with pretreatment may be considered for small noncommunity water supplies. Cartridge filters are usually designed to meet low flow requirements typical of small noncommunity water supplies. It is recommended that preliminary, intermediate, and final cartridge filters be utilized. Cartridge filters can effectively remove particles from water in the size range of *Giardia* cysts (5 – 10 microns) and *Cryptosporidium* (2 – 5 microns). For *Cryptosporidium* removal the following sequence is recommended: a 10 micron (nominal) rated preliminary filter, a 5 micron (nominal) intermediate filter, and a 1 micron (absolute) final filter.

Cartridge filters must be discarded once the particulate loading capacity of the filter is expended. The life expectancy of a cartridge filter is dependent on many factors, including the quality and volume of water being treated and the type of cartridge filter being used. The manufacturers recommended guidelines for cartridge filter replacement should be closely followed. The operation and maintenance costs of cartridge filter replacement must be considered in the design of a cartridge filtration system. Cartridge filters are usually pressure-type filters consisting of a membrane, fabric or string filter medium with particle size removal ranging from 0.2 microns up to 10 microns.

3.3.1 Materials

The materials in contact with the water must not impart undesirable taste, odor, color, and/or toxic materials into the water as a result of the presence of toxic constituents in materials of construction.

System components such as housing, cartridges, membranes, gaskets, and O-rings should be certified for conformance with ANSI/NSF Standard 61. The filter housing shall be constructed to withstand a hydrostatic pressure of 125 psi.

3.3.2 Design

1. The source water or pretreated water should have a turbidity less than 5 NTU.
2. Flow rates should be maintained at less than 1 gpm/sq. ft. of filter area, preferably 0.5 gpm/sq. ft., to minimize pressure loss and increase efficiency. The flow rate through the cartridge filter must not exceed 20 gpm, unless documentation exists

to prove the cartridge filters will meet the requirements for removal of particles at higher flow rates. An automatic fixed flow rate control shall be provided as an integral part of the unit to prevent an influent flow rate in excess of the filtering components' capabilities at any time during its effective life. A totalizing meter should be provided to record daily flow.

3. When various types of cartridges or elements with different purposes and performances are available from the manufacturer, they shall bear differentiating identifications that are easily identifiable and clearly visible. Such identification shall be fully explained on the package containing the element or cartridge.
4. Waste connections or outlets, if provided, should be through an air gap of not less than 1 inch. Special attention must be given to prevent the potential for cross connection backflow/between untreated and treated water.
5. The dispensing spout, faucet, or outlet for treated water shall be designed, constructed, and located such that when the unit is installed in conformance with the manufacturer's instructions, it is directed downward and readily accessible for use.
6. The cartridge filtration unit shall be constructed or equipped to preclude operation beyond the effective life of the filter cartridge. This may be accomplished by one of the following means:
 - a. the unit becomes inoperable when the effective life of the cartridge is reached, or
 - b. the unit is provided with an easily visible and readily interpretable means of guiding the operator in determining the effective life of the cartridge.
7. Frequent start and stop operation of the cartridge filter should be avoided. One of the following operations is recommended to avoid frequent start and stop cycles:
 - a. a slow opening and closing, valve ahead of the filter to reduce flow surges.
 - b. reduce the flow through the cartridge filter to as low as possible to lengthen filter run times.
 - c. install a recirculating pump that pumps treated water back to a point ahead of the cartridge filter.
8. A pressure relief valve should be incorporated into the cartridge filter housing.
9. Pressure gauges must be provided before and after each filter element to properly monitor system pressure loss.

3.3.3 Installation

1. All units shall be readily accessible for maintenance, service, inspection, and cleaning. The cartridges, filter elements and other replacement components shall be readily removable and easily replaced.
2. Spare cartridges, filter elements, and other replacement components are to be provided to allow prompt replacement and/or repair by a qualified person properly instructed in the operation and maintenance of the equipment.

PART IV

CHAPTER 4 - CHEMICAL HANDLING AND FEEDING

4.0 General

Under DEP regulations, all chemicals or materials (i.e. paints, liners, etc.) which may come in contact with the raw or finished drinking water must be acceptable to DEP. Reference should be made to Section 1.7 of these design standards.

4.1 Feeding Equipment

- a. Suitable means shall be provided to insure proper and continuous chemical dosage of the water being treated.
- b. Variation in the accuracy of the feed rate shall not exceed five percent of the intended dosage.
- c. The discharge of a chemical solution feeder shall be equipped with a suitable valve to prevent siphonage of the solution and the valve shall be located above the flood rim of the solution tank.
- d. A no-flow switch shall be provided to prevent the feeding of such chemical solutions upon cessation of water flow.

4.2 Solution Tanks

- a. Where used, solution tanks shall be provided with continuous agitation to keep the strength of the solution uniform throughout.
- b. The pipes supplying water for the dissolving of chemicals, or for make-up water, shall be introduced via an air gap or other approved method for preventing back-siphonage.
- c. Chemical solution tanks shall be provided with suitable covers and should be of sufficient capacity to provide at least one day's (24 hours) storage.

4.3 Chemical Feed Lines

Chemical feed lines shall be easily accessible for repair or cleaning; protected against damage and freezing; corrosion resistant; as short as possible; and be provided with adequate slope to permit draining.

4.4 Handling of Chemicals

Where applicable, as determined by DEP, such safety equipment as an approved respirator, rubber or neoprene gloves and apron, and goggles shall be provided.

4.5 Operator Safety

Operator's of NCWSs should reference the safety requirements specified in the Public Water Supply Manual, Part II – Community Water System Design Standards. The American Water Works Association's Manual M-3, "Safety Practices for Water Utilities" should also be used as a guide for operator safety.

PART IV

CHAPTER 5 - FINISHED WATER STORAGE

5.0 General

Finished water storage should be provided as an integral part of each noncommunity water system and meet the following requirements:

- a. The location, size and type of storage facility shall provide a minimum pressure of 25 psig;
- b. All storage facilities shall be designed to permit dewatering for cleaning and maintenance;
- c. Each reservoir, standpipe, or elevated tank shall be provided with a suitable watertight roof or cover;
- d. Each hydropneumatic storage tank shall be provided with an adequate pressure relief valve and air volume control, and shall have a rated working pressure in excess of the maximum system pressure;
- e. All vents shall be protected with down-facing elbows or mushroom-type caps fitted with insect screens;
- f. All protective coatings or liners which come in contact with potable water shall be acceptable to DEP;
- g. All reservoirs, tanks and appurtenances shall be disinfected in accordance with American Water Works Association's Standard for Disinfection of Water-Storage Facilities prior to being placed into service.

5.1 Elevated or Standpipe Storage

Elevated or standpipe storage should be provided where usage exceeds 30,000 GPD. Storage at least equal to average daily demand is recommended.

5.1.1 Standards

Storage tanks should conform to the following:

- a. Constructed in accordance with the appropriate American Water Work Association's standards;
- b. Painted in accordance with American Water Work Association's Standards or by using a paint or coating acceptable to DEP;
- c. Disinfected prior to being placed into operation in accordance with American Water Works Association's Standard for Disinfection of Water Storage Facilities.

5.1.2 Design Criteria

- a. The head range of the elevated tank should not exceed 30 feet.
- b. The tank must be provided with an overflow which is brought down to an elevation of 12 to 24 inches above ground surface, and discharged over a drainage inlet or splash plate.
- c. The tank should include entrance manholes with locked hatches, a screened vent and an OSHA-approved access ladder.
- d. The piping and valving arrangement must be such that it will allow the tank to be removed from service.
- e. A drain must be provided.
- f. The tank shall not have a direct connection to a sewer or storm drain.
- g. Security measures should be provided including chain link fence, aircraft warning light, etc. as appropriate.
- h. A low-level warning light and/or alarm should be provided.
- i. A suitable control system must be provided (i.e., telemetering).

5.2 Hydropneumatic Storage

Hydropneumatic storage is considered primarily as an electrical pump control mechanism and not as true storage.

5.2.1 Design and Installation

Hydropneumatic tanks and their installations shall conform to the following:

- a. Gross volume in gallons of the hydropneumatic tank should be at least 10 to 15 times the capacity (in GPM) of the largest supplying pump;
- b. Delivery volume in gallons of water from bladder type hydropneumatic tank(s) should be at least three times the capacity (in GPM) of the largest supplying pump;
- c. The tanks should be installed above normal around level. Earth mounding over the tank is not recommended;
- d. Tanks less than 1,000 gallons should be completely housed and heated for protection from both physical damage and freezing;

- e. Tanks must be provided with a bypass to permit operation of the system when they are out of service;
- f. Tanks shall be provided with a drain, a pressure gauge, an air blow-off, means of adding air, and a pressure-activated off/on switch to control the supply pump;
- g. Tanks of 1,000 gallons capacity and larger shall be provided with a manhole;
- h. The tanks shall meet ASME code requirements and/or state and local laws and regulations for unfired pressure vessels.

5.3 Ground Level Storage

5.3.1 Design and Installation

- a. The bottom of the tank shall be above the normal groundwater table and the maximum flood level.
- b. The tank should be constructed no closer than 50 feet to sewers, drains, standing water and other sources of pollution.
- c. The tank shall be watertight and constructed to prevent entry of birds, animals, insects, and excessive dust.
- d. Security should be provided by fencing, locks and other measures as required to prevent trespassing and vandalism.
- e. The tank shall not have a direct connection to a sewer or storm drain.
- f. A screened vent should terminate in an inverted U at least 24 inches above ground level.
- g. An access manhole should be located above the waterline of the tank. The access manhole shall be framed at least four inches above the surface of the roof and fitted with a solid, watertight, locked cover which overlaps the framed opening at least two inches.
- h. A screened overflow must be installed to have a minimum air gap of 12 inches above a splash block located at ground surface. The overflow shall not connect directly to a sewer or storm drain.
- i. Grading shall be such that surface water drains away from the tank.

5.3.2 Standards - Fiber Glass Tanks

Fiberglass storage tank installations shall have the following exceptions and additions to the above:

- a. Tanks should be pressure tested according to manufacturer's instruction and fittings soap bubble tested prior to use;
- b. Tanks shall be anchored to a concrete pad and backfilled with pea gravel material meeting manufacturers recommendations;
- c. Combined weight of the empty tank, the concrete pad and the backfill supported on the concrete pad shall be sufficient to prevent flotation of the empty tank.

PART IV

CHAPTER 6 - PUMPING EQUIPMENT

6.0 General Design

- a. Pumps and appurtenant equipment shall be designed and installed to insure a contamination-proof and frost-proof installation.
- b. Each well pump shall be provided with a foot-valve or, where appropriate, a priming chamber or vacuum-producing device to prevent cavitation.
- c. In a screened well, the pump setting and suction inlet shall be located so that the pumping level of the water cannot be drawn below the top of the screen.
- d. Suction lift pumps should not be used where the maximum suction head exceeds 22 feet.

6.1 Location

- a. When possible the pump shall be located and designed to avoid the use of a pump pit. A pump pit, if used, shall be of watertight construction to avoid flooding.
- b. The location shall permit convenient access for the removal and repair of the pump, drop pipe and other accessories.
- c. The pump shall be suitably mounted to avoid objectionable vibration and noise, and to prevent damage to pumping equipment.
- d. The pump controls and/or accessories shall be protected from weather.

6.2 Pump Controls

The following controls are required on all pump installations:

- a. Pressure switch;
- b. Thermal overload switch;
- c. Pressure relief valve on positive displacement pumps.

PART IV

CHAPTER 7 - DISTRIBUTION SYSTEMS

7.0 General Requirements

- a. All service lines and distribution mains intended for year-round water service should be provided with sufficient earth cover to prevent freezing.
- b. All new service lines and distribution mains must be adequately disinfected in accordance with American Water Works Association's Standard for Disinfection of Water Mains prior to being placed into service.
- c. Distribution mains are to be laid using the loop system to eliminate dead ends when practicable. Dead ends, if unavoidable, shall be provided with a flushing hydrant or blowoff for flushing purposes. Each such flushing device shall be adequately protected against damage and contamination, should extend at least 12 inches above grade, and provided with an independent self-draining shut-off valve.
- d. Every service line shall be horizontally separated at least five feet from a sanitary sewer, 10 feet from a septic tank, distribution box, disposal field or seepage pit, and 25 feet from a cesspool, by undisturbed or compacted earth.
- e. Distribution mains shall generally be separated from sanitary sewers by a horizontal distance of 10 feet. If such lateral separation is not possible, the bottom of the distribution main shall be at least 18 inches above the top of the sewer.